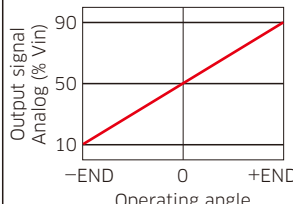
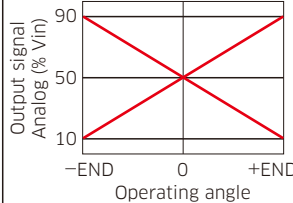
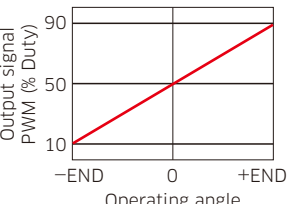
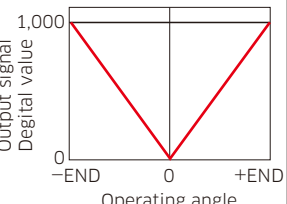
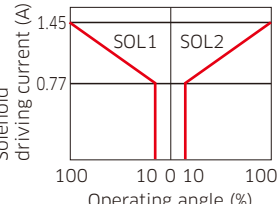
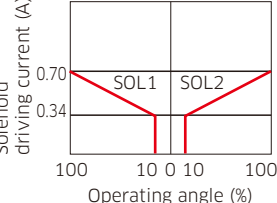

Type of Electrical Output

Type of Output	Analog	PWM	CAN **	Solenoid Driver
Input Voltage	5V	12V	12V / 24V	12V / 24V
Output Signal	<p>Standard type</p>  <p>Fail safe type</p> 			<p>12V type</p>  <p>24V type</p> 

** Under development

➤ Solenoid Driver

Proportional switch

Solenoid driver

Solenoid driver is built in the handle.
When a controller is not set in the machine, this solenoid driver can drive directly the reducing valve to control flow.

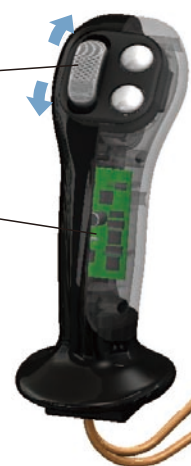

The proportional switch on the handle gives signal to the solenoid driver that drives directly the reducing valves.

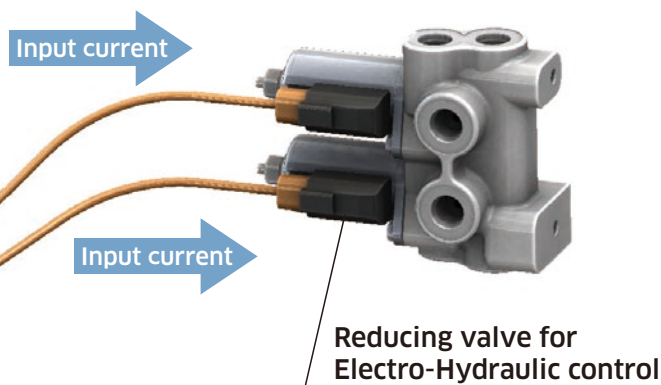

●Materials and specifications are subject to change without manufacturer's obligation.

Kawasaki Heavy Industries, Ltd.

Precision Machinery Company

<http://www.khi.co.jp/kpm/>

Tokyo Head Office

1-14-5 Kaigan, Minato-ku, Tokyo 105-8315, Japan
Phone +81-3-3435-6862 Fax. +81-3-3435-2023

Kobe Head Office

Kobe Crystal Tower, 1-3 Higashikawasaki-cho 1-chome, Chuo-ku, Kobe 650-8680, Japan
Phone +81-78-360-8607 Fax. +81-78-360-8609

Nishi-kobe Works

234, Matsumoto, Hasetani-cho, Nishi-ku, Kobe 651-2239, Japan
Phone +81-78-991-1160 Fax. +81-78-991-3186

Kawasaki Precision Machinery (UK) Ltd.

Ernesettle Lane, Ernesettle, Plymouth, Devon, PL5 2SA United Kingdom
Phone +44-1752-364394 Fax. +44-1752-364816
<http://www.kpm-eu.com>

Kawasaki Precision Machinery (U.S.A.), Inc.

3838 Broadmoor Avenue S.E. Grand Rapids, Michigan 49512, U.S.A.
Phone +1-616-975-3100 Fax. +1-616-975-3103
<http://www.kpm-usa.com>

Kawasaki Precision Machinery Trading (Shanghai) Co., Ltd.

17th Floor (Room 1701), The Headquarters Building, No168, XiZang Road (M), Huangpu District, Shanghai, 200001, China
Phone +86-21-3366-3800 Fax. +86-21-3366-3808

Flutek, Ltd.

98 GIL 6, Gongdan-Ro, Seongsan-Ku, Changwon-Si, Kyungnam, 51567, Korea
Phone +82-55-210-5900 Fax. +82-55-286-5557

Wipro Kawasaki Precision Machinery Private Limited

No. 15, Sy. No. 35 & 37, Kumbalgotu Industrial Area, Kumbalgotu Village, Kengeri Hobli, Bangalore, - 560074, India

Electric Remote Controller ERU series

ERU Series is Kawasaki designed electric control unit perfectly suit to the electric control system especially for mobile applications.



Features

1. High reliability and less friction, using non-contact type potentiometer.
2. Electromagnetic noise-proof construction with ISO11452 series standard etc.
3. Environmental worthiness and Water-proof construction can be functional in any circumstances.
(Operating temperature range : -40~75°C)

Dual Axis Type electric control base and handle

ERU2

ERU2 is dual axis type electric control base.

Model Code

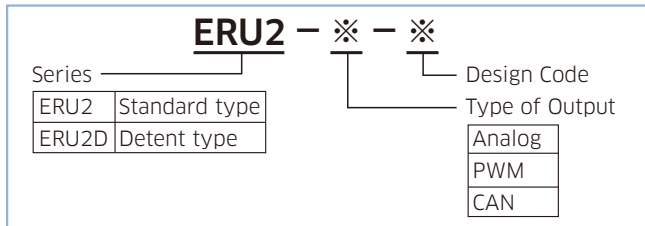

Specifications

Series	ERU2	ERU2D
Operating Torque (Nm)	Refer to "Operating Torque and Angle"	
Operating Angle (°)	Refer to "Operating Torque and Angle"	
Temperature range (°C)	-40 ~ 75	
Type of Output	Refer to P.4 "Type of Electrical Output"	

Operating Torque and Angle

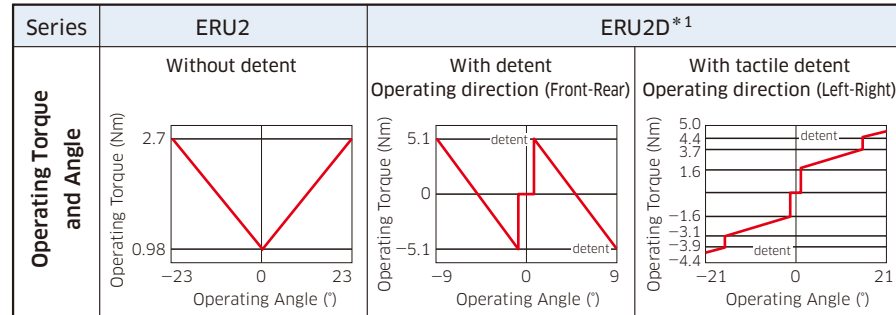

*1 ERU2D has two types of detent functions and can be operated in two axial directions, Left-Right-axis and Front-Rear-axis.

Dimension

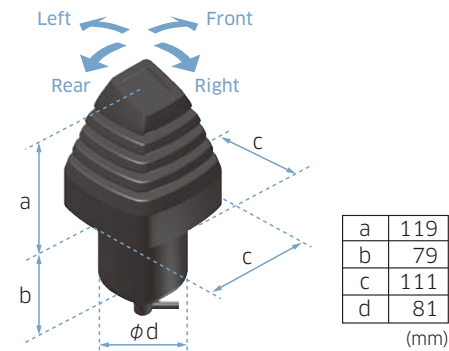

ERUH, ERUHM

ERUH and ERUHM can be attached with electric control base "ERU2".

For various type of application control, ERUH&ERUHM own variety of switches.

Model Code

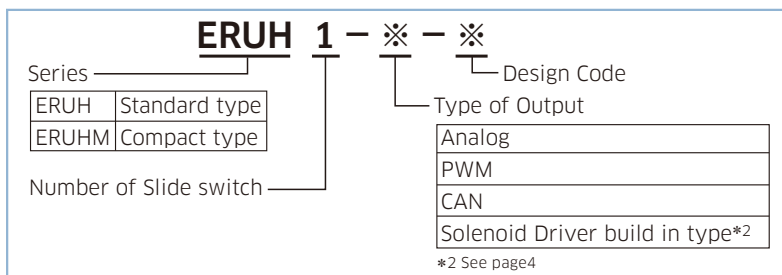

Dimension

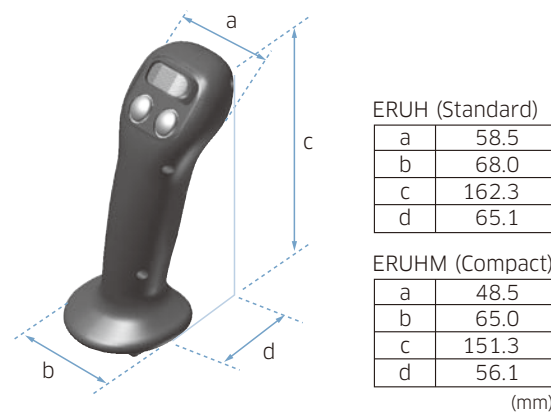

Specifications

Series		ERUH / ERUHM			
Slide Switch	Operating Torque (mNm)	Min.	17	19	18
		Max.	35	46	68
Operating Angle (°)		±13			
Temperature range (°C)		-40 ~ 75			
Type of Output		Refer to P.4 "Type of Electrical Output"			

Switch Variation

Combination of the switches	Front						Rear	
	W/O Slide switch		With Slide switch				Trigger switch	Rocker switch
	ON/OFF*3 switches		ON/OFF with Slide switch		Slide switch			
			Top	Left	Right	Top	Left	Right
Series	Number of the ON/OFF switches			Number of the switches				
ERUH	0 ~ 4			0 ~ 2			0 ~ 2	0 ~ 1
ERUHM	0, 1, 3			0 ~ 2			-	-

*3 : ON/OFF switch position can be changed. Please consult with Kawasaki.

Operating Torque and Angle

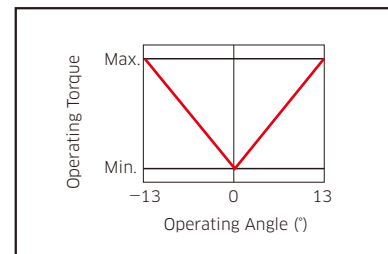

Single Axis Type electric control unit

ERUP

ERUP is the Pedal type electric remote control base.

Model Code

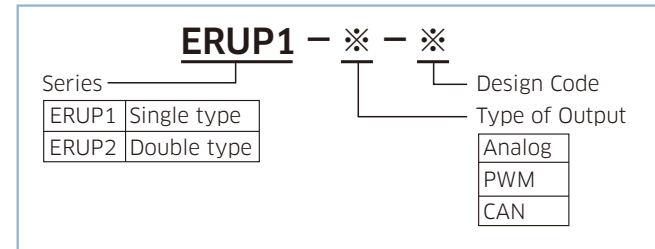

●ERUP1 has a pedal with an option.

Specifications

Series	ERUP1	ERUP2	
Operating Torque (Nm)	Min.	4.9	6.5
	Max.	8.8	15.3
Operating Angle (°)	±12.4		
Damper	without	with	
Temperature range (°C)	-40 ~ 75		
Type of Output	Refer to P.4 "Type of Electrical Output"		

Operating Torque and Angle

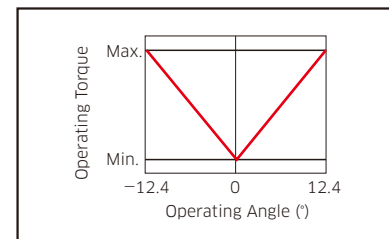

ERUS

ERUS is electric control unit of the single axis.

Model Code

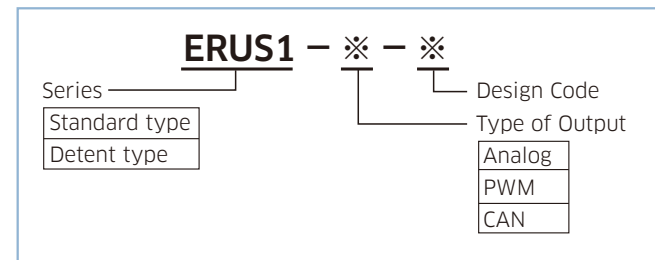

Specifications

Series	ERUS1		
Type	Standard	With Detent	
Operating Torque (Nm)	Min.	0.7	1.2
	Max.	1.9	3.5
Operating Angle (°)	±11	±21.5	
Temperature range (°C)	-40 ~ 75		
Type of Output	Refer to P.4 "Type of Electrical Output"		

Dimension

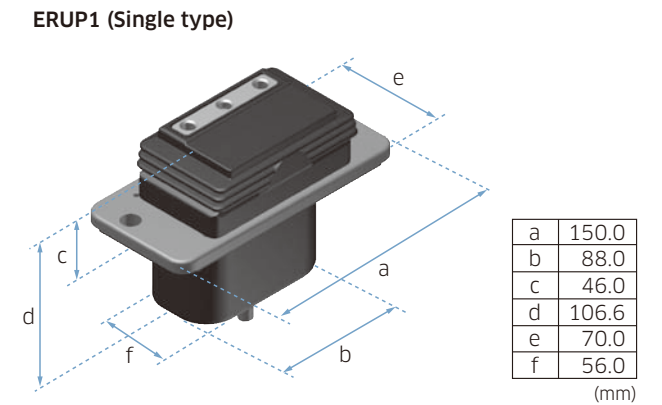

ERUP2 (Double type)

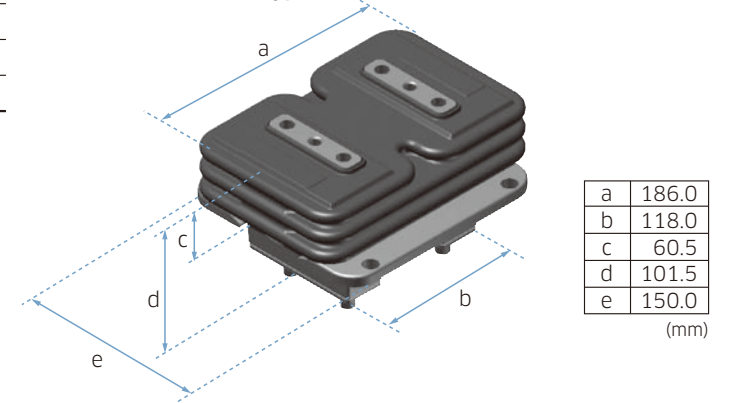

Dimension

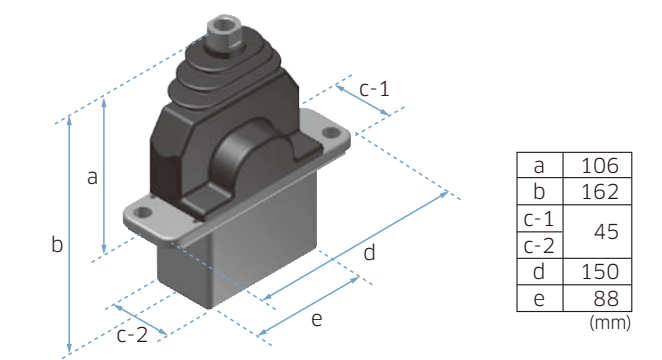

Operating Torque and Angle

